

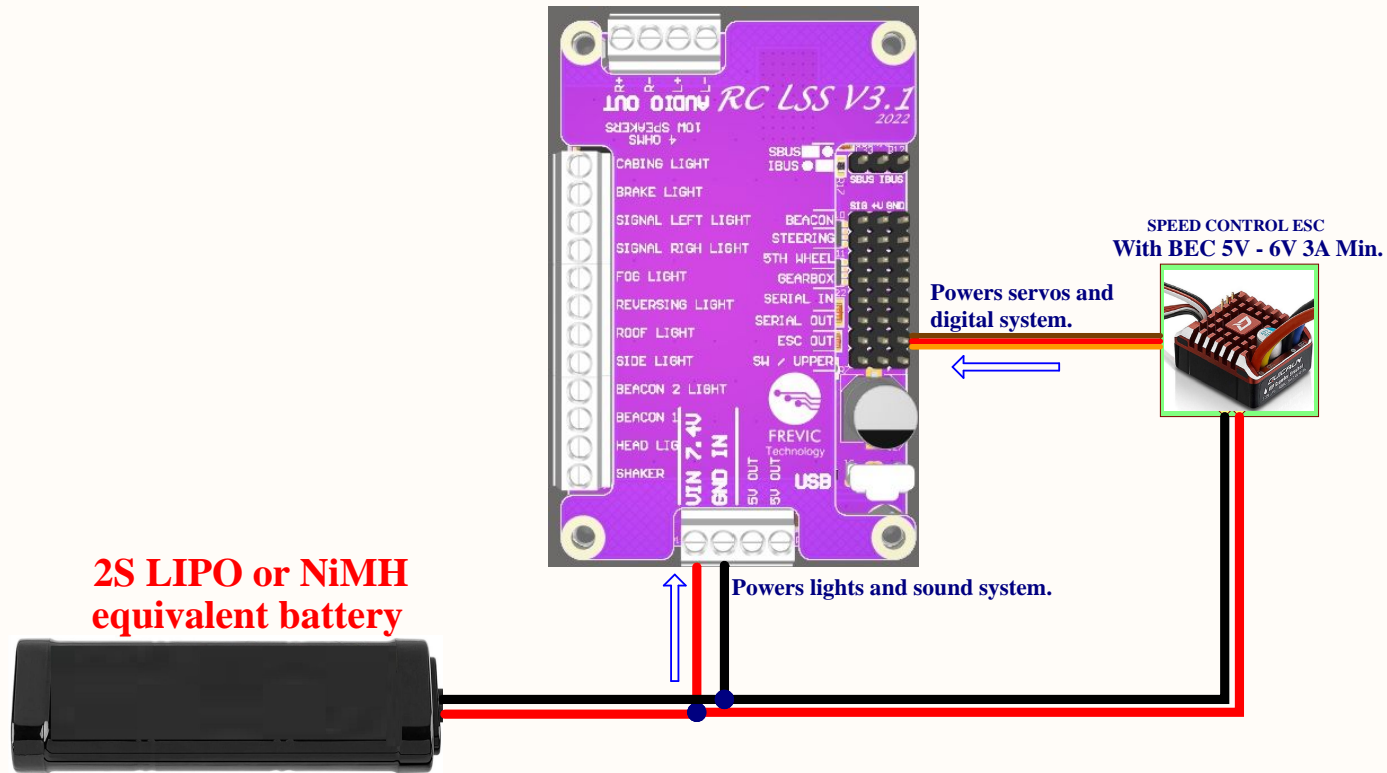

# RC Light and Sound System V3.1



Title <b>RC Light and Sound System</b>		FREVIC TECH		
Size: Letter	Version: 3	Revision: 1		
Date: 19/04/2023	Time: 09:36:32 a.m.	Sheet 1 of 4		
Engineer: FREVIC Engineering				

# Power Supply Diagram



Title <b>RC Light and Sound System</b>			FREVIC TECH Colombia	
Size: Letter	Version: 3	Revision: 1		
Date: 19/04/2023	Time: 09:36:32 a.m.	Sheet 2 of 4		
Engineer: FREVIC Engineering				

# Connection Diagram

**MAX TOTAL 50 LEDS**  
**MAX 10 LEDS BY CHANNEL!**

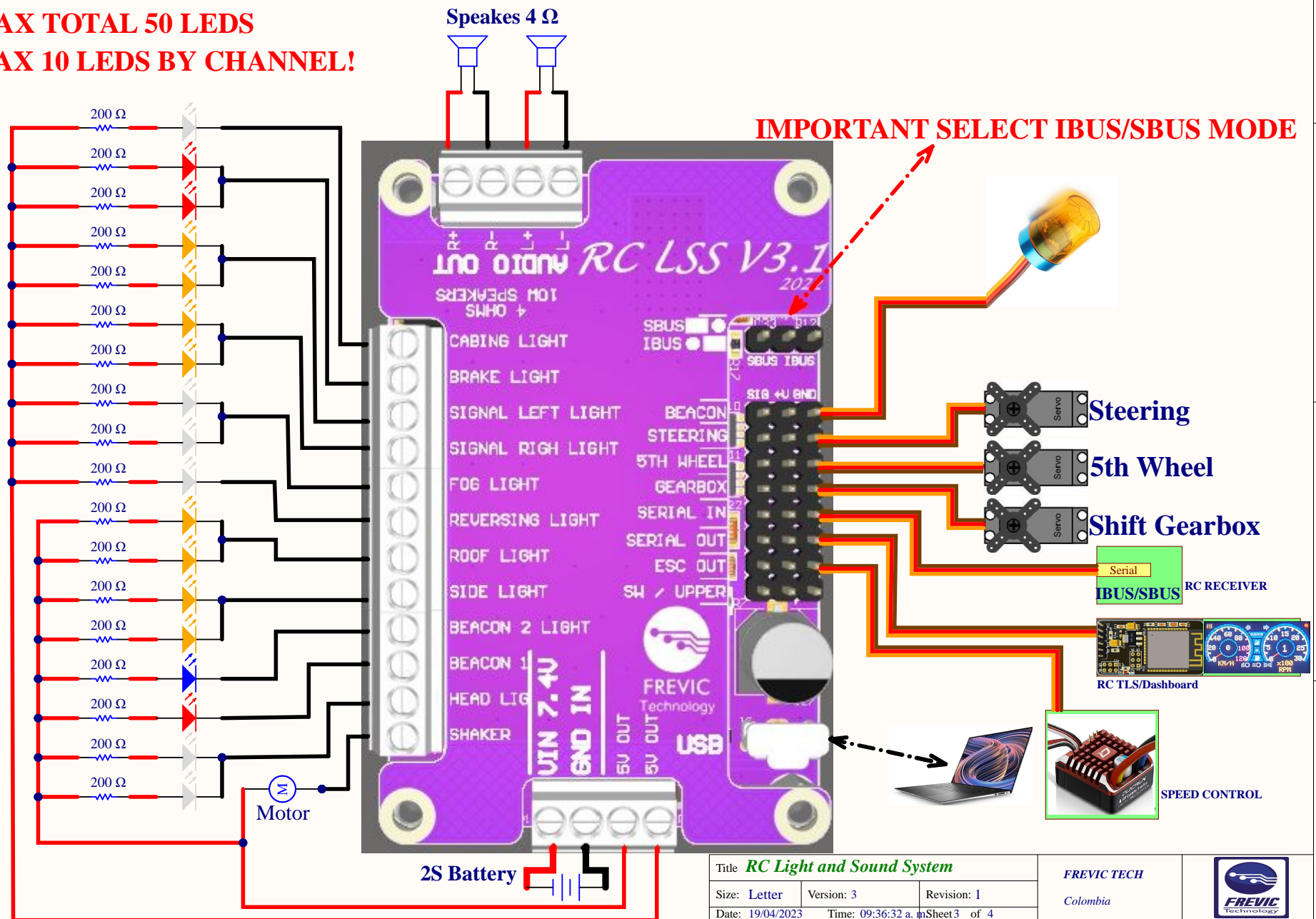

Title <b>RC Light and Sound System</b>			FREVIC TECH Colombia	
Size: Letter	Version: 3	Revision: 1		
Date: 19/04/2023	Time: 09:36:32 a.m.	Sheet 3 of 4		
Engineer: FREVIC Engineering				

# Radio Adjustment

## FLYSKY FS-i6X

Joystick, button, potentiometer				Function	
Remote channel	Name	Direction	Duration	Switch A up (100% DR)	Switch A down (75% DR)
1	Stick horizontal right			Steering	
6	Switch C (3 pos.)			Gearbox shifting	
3	Stick vertical left			Throttle & brake	
5	Pot B "VrB"			Horn, bluelight & siren / beacons	
2	Stick vertical right	up	togggle long	High / low beam	light state up
			toggle		
			momentary	Headlights flasher	
		down	togggle long	volume level	Engine on / off
			toggle		
			momentary	Jakebrake	
4	Stick horizontal left	left	togggle long		hazards
			toggle	left indicator on / off	
			momentary		
		right	togggle long		5th wheel unlocking (3
			toggle	right indicator on / off	
			momentary		
7	Switch D			Transmission neutral	

Recommended internal ESC & settings (use programming card) for TAMIYA trucks with 3 speed transmission: ESC: HOBBYWING 1080 QUICRUN WP (Recommended) Crawler Brushed with the following settings:

- 1: 3 ;
  - 2: 1 ;
  - 3: 3 ;
  - 4: 3 ;
  - 5: 4 ;
  - 6: 2 ;
  - 7: 9 ;
  - 8: 1 ;
  - 9: 8 (change it, important) ;
  - 10: 4 ;
  - 11: 4 ;
  - 12: 5 ;
  - 13: 4 ;
  - 14: 1 (be careful here!!) ;
  - 15: 1 (change it, important)
- Motor: 540 size, 35 turns, stock pinion

DR = Dual Rate (signal range, 100% = 1000 - 2000ms, 75% = 1125 - 1875ms)  
 Switch A is transmitter internally used for DR switching: CH2 & 4 "Normal" = 100, "Sport" = 75:  
 >Functions setup > Dual rate/exp.

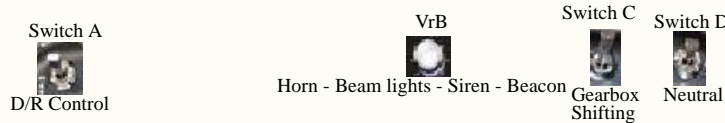

Title <b>RC Light and Sound System</b>			FREVIC TECH Colombia	
Size: Letter	Version: 3	Revision: 1		
Date: 19/04/2023	Time: 09:36:32 a.m.	Sheet 4 of 4		
Engineer: FREVIC Engineering				